



ASSEMBLY INSTRUCTIONS: BULLSEYE

ASSEMBLY INSTRUCTIONS: BULLSEYE

Removal of the old pane

1. Screw off the cover ring.
2. Screw off wheel nut completely
3. Pull off pressure pane
4. Pull off gasket by force
5. Cut one axle with suitable side cutter
6. Swivel out the pane
7. Push out the axle residue from the inside to the outside

Assembly of the sealing ring 7214094

1. Fit gasket onto pane and fix holes to match
2. Mount thrust pane and ratchet nut as described in pos. 2 and 3 in reverse order
3. Swivel in complete pane on the existing axle and hammer in new axle on the opposite side

Mounting the complete pane 7214093

1. Swivel in complete pane on the existing axle and hammer in new axle on the opposite side

**If you get stuck at any point in the instructions, send us the complete bullseye.
We will professionally insert the desired parts for you.**

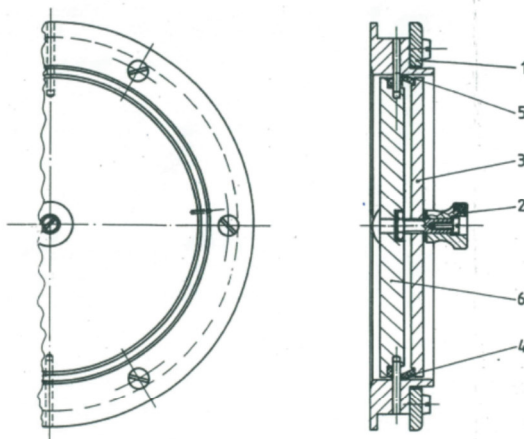

Removal of the old pane

1. Screw off cover ring and remove bullseye completely.
2. Screw off wheel nut completely.
3. Pull off pressure pane.
4. Pull off gasket by force.
5. Cut one axle with suitable side cutter.
6. Swivel out the pane.
7. Push out the axle residue from the inside to the outside.

Assembly of the sealing ring 72140 94

- Fit gasket onto pane and fix holes to match.
 - Mount thrust pane and ratchet nut as described in pos. 2 and 3 in reverse order.
- Swivel in complete pane on the existing axle and hammer in new axle on the opposite side.

Mounting the complete pane 72140 93

- Swivel in complete pane on the existing axle and hammer in new axle on the opposite side.

If you encounter problems, send us the complete bullseye.
We will professionally insert the desired parts for you.
Sollten Sie Probleme bekommen, senden Sie uns die komplette Bullseye zu.
Wir setzen Ihnen die gewünschten Teile gerne fachmännisch ein.

| | | | | | |
|------|--|------|--|--------------------------------------|--|
| Date | | Name | | Herkunft | |
| Date | | Name | | PFEIFFER MARINE | |
| Date | | Name | | Mounting instructions for the swivel | |
| Date | | Name | | 72140 | |